

TunnelTech 401

Road Tunnel Atmosphere Monitoring Systems

NO₂ , CO NO and Visibility Air Quality Monitor

- Continuous measurement of NO₂, CO, NO and Visibility in road tunnels
- High accuracy determination of NO₂ down to low ppb levels (0-1000ppb)
- Electrochemical CO monitor, 0-500 ppm, accuracy +/- 2% FSD
- Electrochemical NO monitor, 0-300 ppm, accuracy +/- 2% FSD
- Visibility monitor (Opacity), 0-0.015m⁻¹, accurate to +/- 0.0002m⁻¹
- Extractive analyser for easy maintenance and calibration
- Minimal maintenance requirements, low cost of ownership
- Panel mount PC for commissioning, control and diagnostics
- RS485 (MODBUS) and Ethernet output
- Three analogue and relay outputs
- Auto zero and span check of NO₂ , CO and NO by audit gas



TunnelTech 401 - NO₂, CO, NO and Visibility Air Quality Monitor

The CODEL TunnelTech 401 NO₂, CO, NO and Visibility Air Quality Monitor is a compact extractive analyser configured for the continuous measurement of four key parameters in road tunnels. This extremely stable and reliable monitor incorporates an LED to utilise the capacity of Nitrogen Dioxide to absorb UV and blue light to provide accurate readings in parts per billion. It also uses the same sampling system to monitor Visibility using a unique double sensor design. Two Electrochemical cells are also added to the sampling cell to measure CO and NO.

NO₂, CO, NO and particulate are produced naturally by the combustion processes within the internal combustion engine and are emitted from the exhausts of all types of vehicles. NO₂ is also particularly toxic and prolonged exposure to levels as low as a few hundred parts per billion will have a detrimental effect on human health. There is a growing international requirement to measure and limit the levels of NO₂ within road tunnels to reduce the exposure of tunnel users to this toxic gas.

CO and NO also present a hazard to health but at much higher levels than NO₂ and are now more of a nuisance to tunnels users. Visibility monitoring has two functions, to ensure that drivers can sufficiently see the road ahead to drive safely and to protect users from ingesting fine particles (<10µm) that may be carcinogenic.

The TunnelTech 401 can also play an important role in reducing energy usage within road tunnels. When employed to control tunnel ventilation systems, they can significantly reduce the use of jet fans etc. and thereby reduce energy use and its significant costs.

The TunnelTech 401 NO₂ monitoring system utilises a very accurate measurement technique. NO₂ absorbs UV and blue light very strongly; the TunnelTech 401 uses a precision transmissometer which measures the attenuation of UV and blue light by NO₂ in the tunnel atmosphere. The light source is a near-infrared LED and the interfering effects of particulate in the tunnel atmosphere are eliminated by making the measurement within a metre long diffusion cell within the main sampling tube. NO₂ diffuses through sintered stainless steel filters to remove the particulate.

The TunnelTech 401 Visibility monitor uses the same cell and fan but has a separate LED source and detector system to monitor changes in light transmission through the sample cell. The CO and NO monitor is an Electrochemical unit which uses a long life cell. This is mounted on a boss on the side of the sampling cell to enable a constantly changing sample to be available to the sensor.

The result of this integration is a very accurate and stable analyser that has very low maintenance requirements. Its key feature is that it is an extractive system that can be mounted outside the tunnel bores in an alcove or machine room. This means that maintenance tasks can be performed whilst the tunnel is in operation with no danger to maintenance staff from passing vehicles.

Fully configurable analogue and alarm outputs are generated inside the Station Control Unit (SCU) which are fully configurable via the door mounted PC. In addition, there is a choice of either RS232 or RS485 outputs which can be utilised to deliver MODBUS protocol to a SCADA system located in the tunnel control centre. There is an Ethernet output for Internet connection, usually by CODEL technicians for diagnostic purposes. A USB port is added for data collection.



TunnelTech 402 in Mont Blanc Tunnel

TunnelTech 401 - Key components

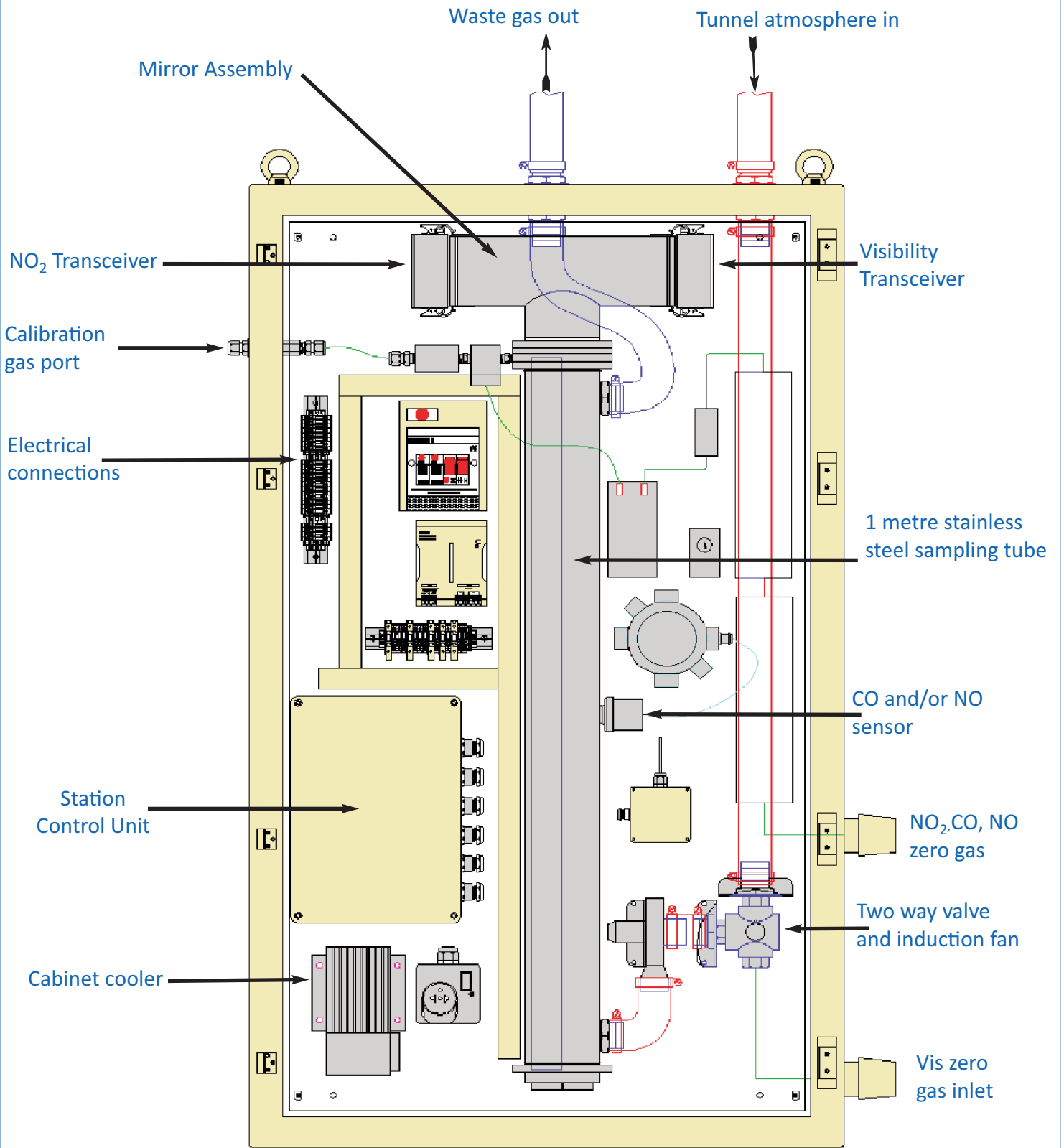

TunnelTech 401 - Key Components

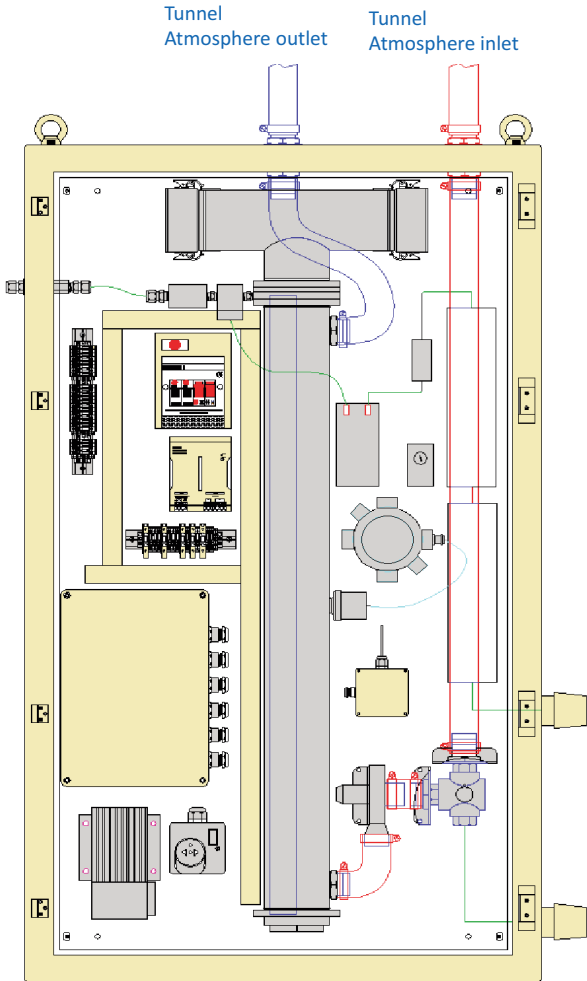

Gas path

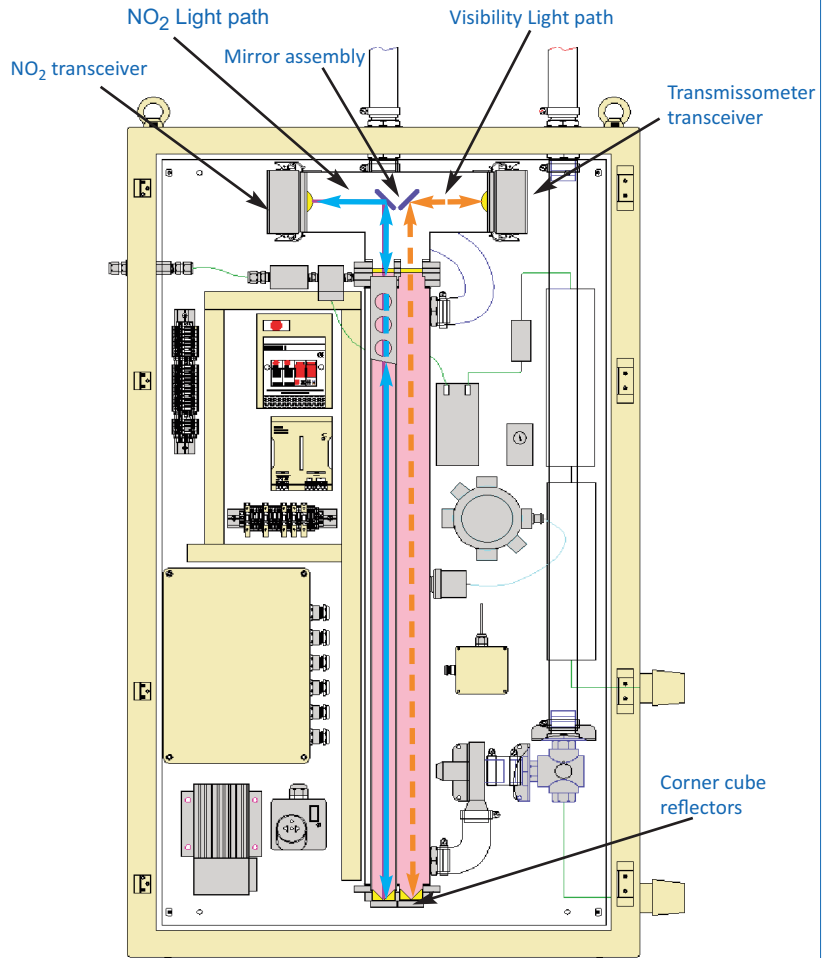

Sensor light paths

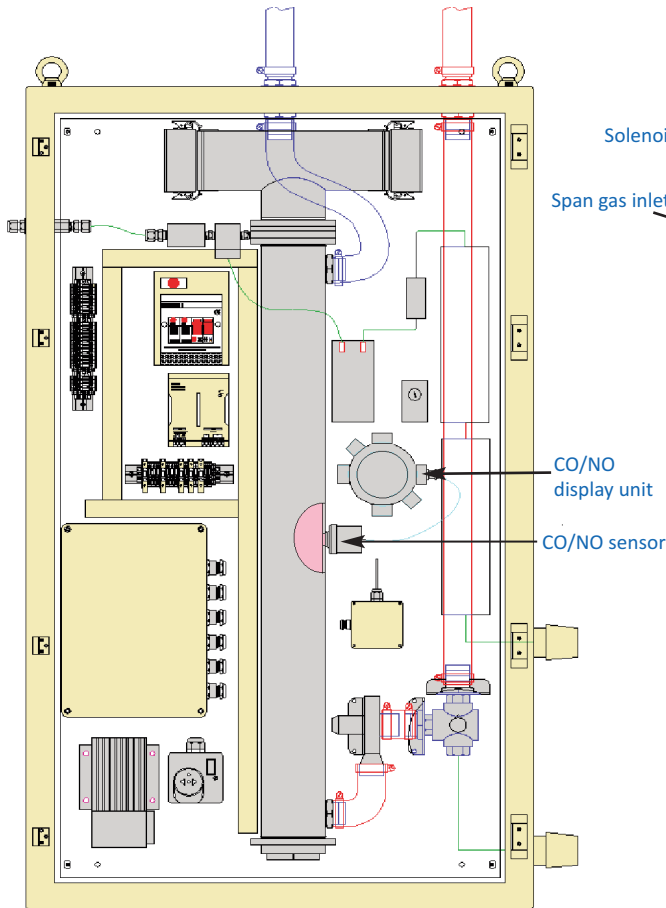

CO/NO sensor

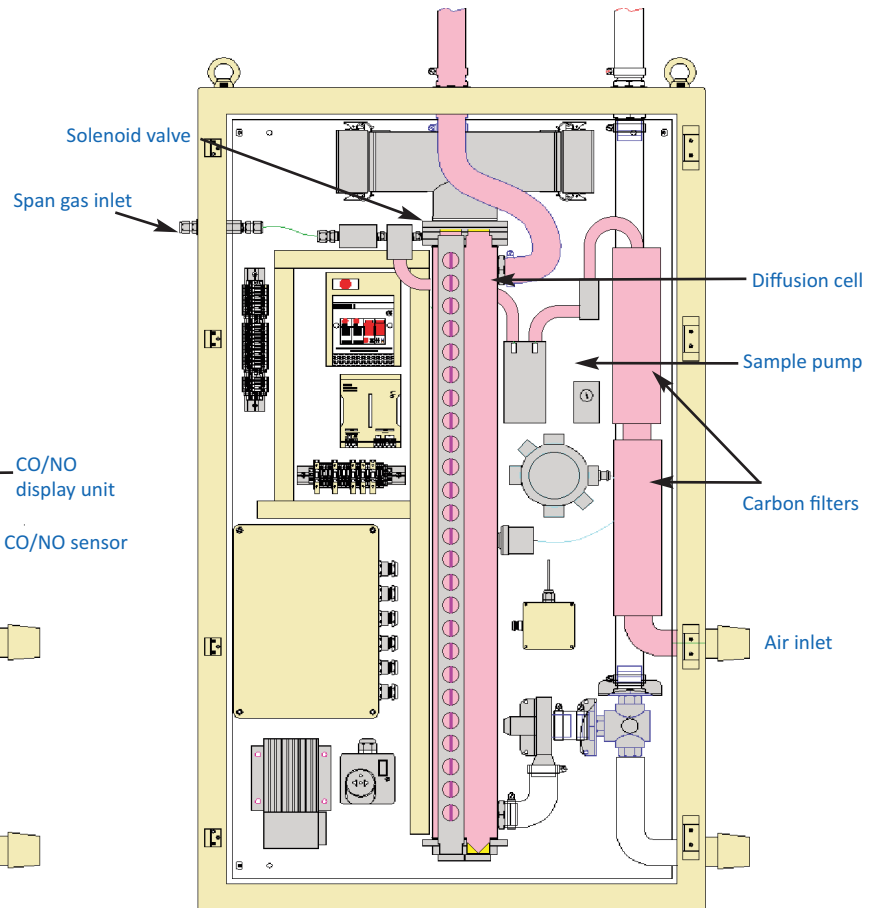

NO₂ calibration system

TunnelTech 401 Enclosure

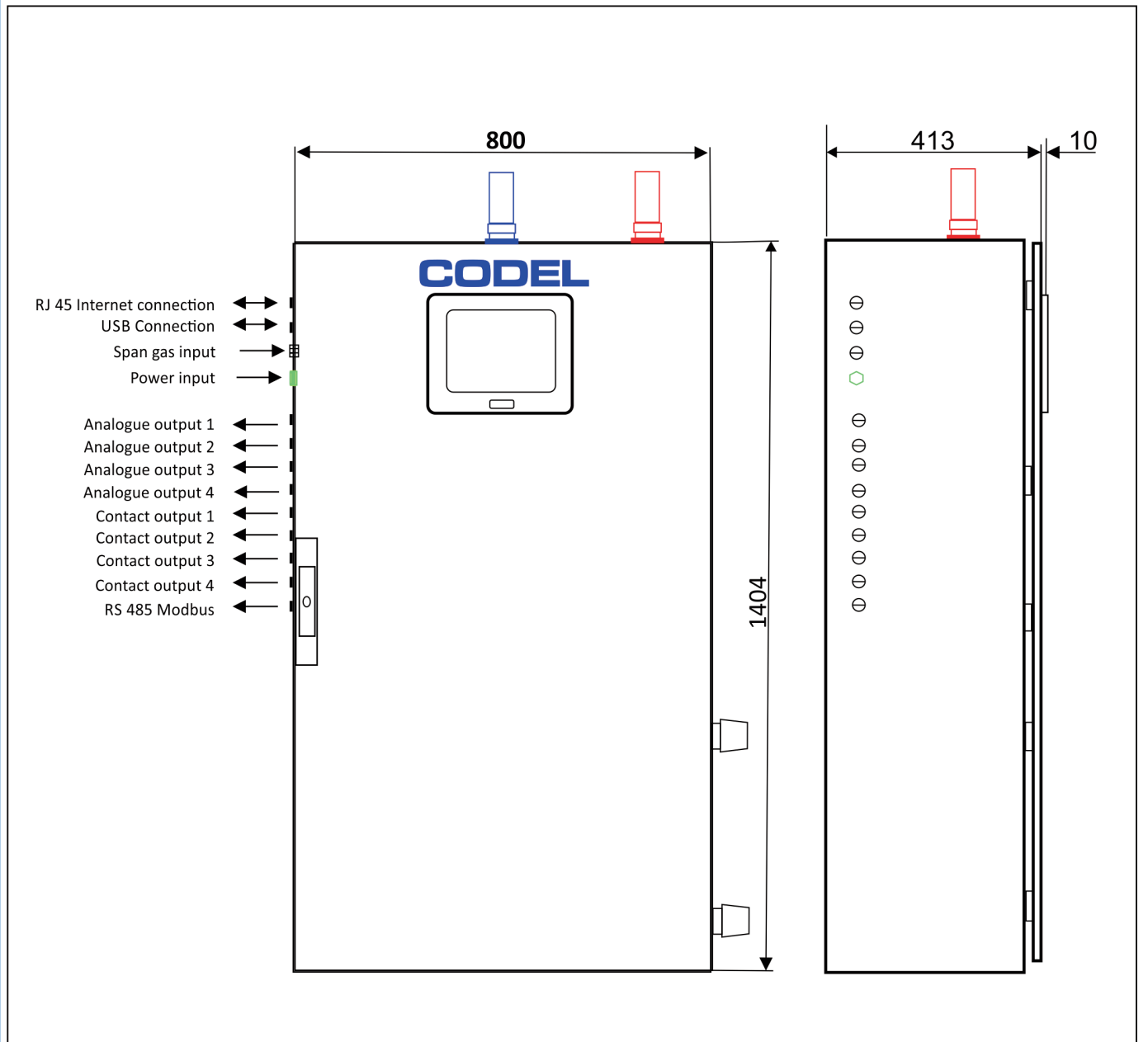

TunnelTech 401 Tunnel mounted components

TUNNEL WALL

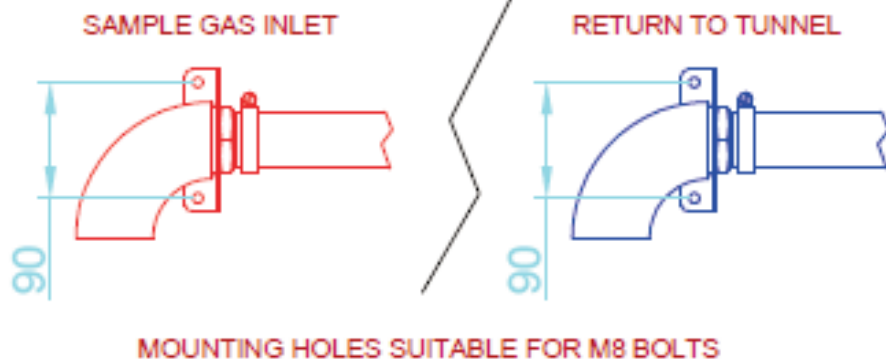

TunnelTech Software

TunnelTech Software is supplied with the TunnelTech 401 for the purpose of commissioning and maintenance of the sensors. The software is accessed through the touch screen, panel mount PC, mounted on the door of the enclosure.

The software enables the sensor's complete data and control functions to be accessed via the screen from the Station Control Unit (SCU). Zero calibrations and span checking can be initiated via the software after commissioning or during a maintenance period. Should it be necessary to alter the initial factory-set current output and relay output configuration then this can also be carried out with ease via the SCU.

For maintenance, the software includes logging and trending of diagnostic data for fault analysis.

TunnelTech Software

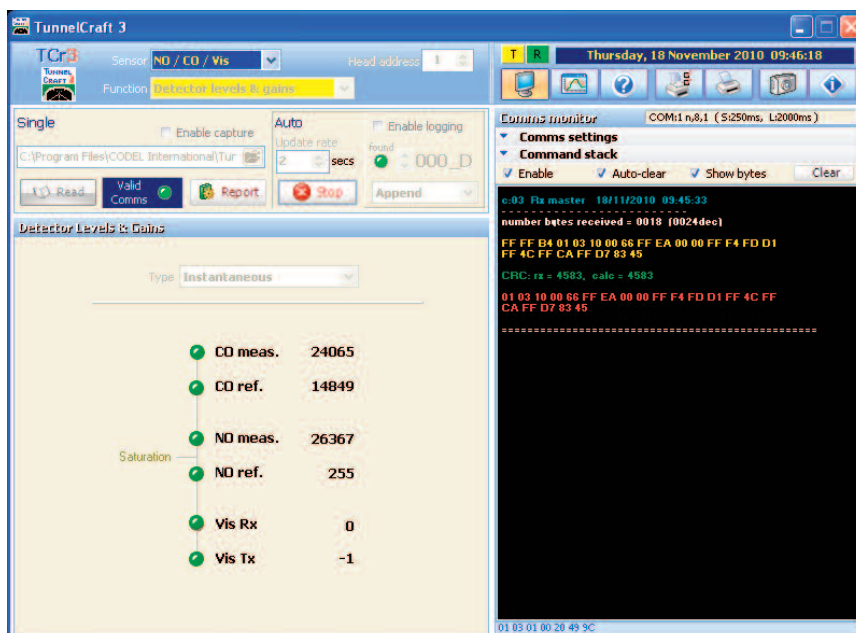
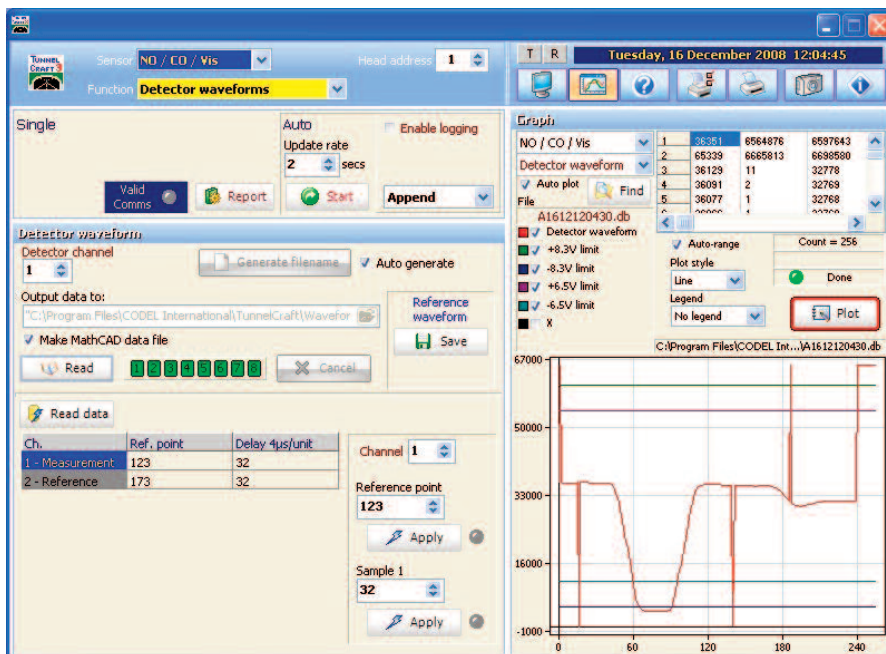

TunnelTech 401 - Technical Specification

Sensor Unit - NO₂

Measurement	Nitrogen Dioxide - (NO) ₂
Measuring units	ppb (Parts Per Billion)
Measurement Principle	Specific absorption of blue light
Light Source	Blue LED
Measurement Path	1m Chamber (2m folded beam)
Measurement Range	0 - 1ppm standard, configurable up to 0 - 5ppm
Accuracy	+/- 0.04ppm
Detection Limit	+/- 0.01ppm
Linearity	Fully linear
Drift	No drift as there is a zero calibration every 24 hours
Response Time	Less than 200 seconds
Data Refresh	1 second
Ambient Temperature	-20 to +50°C
Power Supply	48V DC, 50VA from Station Control Unit (SCU)
Measurement chamber	316L stainless steel, Sensor

Sensor Unit - Visibility

Measurement	Visibility
Units	K factor(M ⁻¹) or metres
Measurement Technique	Transmissometry (de Beer Lambert Law)
Measurement Range (Typical)	0 - 0.015m ⁻¹
Accuracy	+/- 0.0002 m ⁻¹
Resolution	+/- 0.0001 m ⁻¹
Averaging Time	From 10 seconds to 2 Minutes

Sensor Unit - CO

Measurement	Carbon Monoxide, (CO)
Measuring units	ppm (Parts Per Million)
Measurement Principle	Electrochemical cell
Measurement Range	0 - 500ppm
Accuracy	+/- 2% of full scale
Repeatability	+/- 2%

Sensor Unit - NO

Measurement	Nitric Oxide, (NO)
Measuring units	ppm (Parts Per Million)
Measurement Principle	Electrochemical cell
Measurement Range	0 - 300ppm
Accuracy	+/- 2% of full scale
Repeatability	+/- 2%

TunnelTech 401 - Technical Specification

Compliances

EMC	89/336/EEC directive compliant
Low Voltage	73/23/EEC directive compliant

Communications & Outputs

Analogue outputs	4 x 4-20mA, 200V common mode isolation, max. load 500Ω
Logic	4 x volt-free contacts SPCO, 0.25A @ 125V AC, 1A @30V DC, 0.25A @ 100V DC
Communications Port	RS 485 MODBUS
Ethernet Port	RJ45
Data Port	USB

Services

Power	Mains 110/230 VAC single phase 50/60 hz
-------	---

Enclosure

Enclosure	Epoxy coated Steel
Weather proofing	IP 65
Weight	100kg
Size	H1404 x W800 x D414mm

Distributor

--

CODEL International Ltd
Station Building
Station Road
Bakewell
Derbyshire
DE451GE
United Kingdom

Tel : +44 (0)1629 814351
Fax : +44 (0)8700 566307
Web : www.codel.co.uk
Email : sales@codel.co.uk